

LF 1227
Rare Books

THE UNITY OF ENGINEERING
AS ILLUSTRATED BY
TRANSPORT TECHNOLOGY

*Inaugural Lecture of the
Professor of Mechanical Engineering
delivered at the College
on 23 November, 1965*

by

F. T. BARWELL

B.Sc., Ph.D., D.I.C., Wh.Sch., M.I.Mech.E., M.I.E.E., M.I.Loco.E.

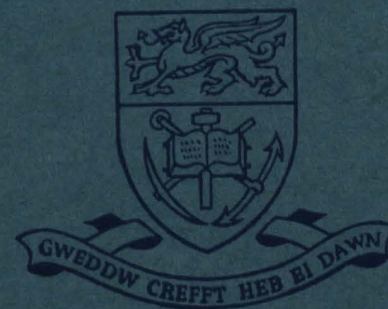

UNIVERSITY COLLEGE OF SWANSEA

Classmark: LF 1227

Accession no: 66/973

Location: Rare Books

SWANSEA UNIVERSITY COLLEGE
LIBRARY

UNIVERSITY COLLEGE OF SWANSEA

THE UNITY OF ENGINEERING
AS ILLUSTRATED BY
TRANSPORT TECHNOLOGY

*Inaugural Lecture of the
Professor of Mechanical Engineering
delivered at the College
on 23 November, 1965*

by

F. T. BARWELL

B.Sc., Ph.D., D.I.C., Wh.Sch., M.I.Mech.E., M.I.E.E., M.I.Loco.E.

Synopsis

Transport, which represents about one sixth of the country's economic activity, makes demands on the skill of all types of engineer and is particularly rich in problems which overlap the traditional division of his subject into Civil, Electrical and Mechanical Engineering. Whereas the product of the transport system, ton miles or passenger miles, can be most economically generated where traffic is concentrated, the demand arises in a diffuse way which has been described by the Holding Company as "small and spread." The need to provide the service over a wide area and yet to carry as much as possible of the traffic in concentrated loads on trunk routes represents the main organisational challenge to the transport industry.

Today's traffic pattern is dominated by the private automobile in which the "small and spread" concept is taken to the limit. Rapid proliferation of this means of transport is giving rise to serious crises in many countries. Professor Morgan has shown necessity for an expenditure on road development of some £7,000,000,000. Necessary though this expenditure is, it will do little to solve the commuter problem of large cities, neither will it provide any great advantage over present standards of motorway speeds. The limit of capacity of the conventional road is something less than 2,000 cars per traffic lane per hour and it can be shown that this limit is due to the need to allow adequate braking distance between each vehicle. The railway track may be more effectively utilised because vehicles can be coupled together and placed under unified control. Modern railway technology is reviewed, particular reference being made to trains of the German Federal Railways which operate at 125 miles an hour and the limitations on further increase in speed are discussed. Understanding of dynamic instability, derived largely from the study of aircraft, can be applied to the design of railway vehicles to eliminate the causes of discomfort often associated with high speed running. Similar laws govern the road holding potentialities of the motor car. Problems of curvature



limit the application of conventional forms of guidance but illustrations are provided of alternative methods based on the use of specially developed pneumatic tyres. The other factor limiting speed is the difficulty of providing sufficient power to overcome the high resistance due to air. An electrical system known as the linear motor may provide the solution here.

The greatest challenge of the future is the application of automation. While this is technically possible for road vehicles, it is more readily applicable to rail vehicles and it is here that progress may be particularly rapid. The research problems which will have to be solved overlap the conventional divisions of engineering and many of them are particularly appropriate to our own School of Engineering at Swansea.

THE UNITY OF ENGINEERING AS ILLUSTRATED BY TRANSPORT TECHNOLOGY

The Transport Problem

I first learned that I would have the privilege of giving this lecture during an early visit when I was very much involved in discussions with Professors Fishwick and Zienkiewicz regarding the future organisation of Engineering at Swansea. The question was "Should there continue to be a single Engineering Department or should it be divided into the conventional areas of Civil, Electrical and Mechanical Engineering?" At the same time I was naturally somewhat preoccupied with problems of transport arising from my duties on the research staff of British Railways Board. It seemed natural to base my lecture on those things which were uppermost in my mind at that time and therefore my title is "The Unity of Engineering as illustrated by Transport Technology."

I propose to adopt as my definition of engineering the classical one which is embodied in its charter by the Institution of Civil Engineers. This reads as follows:

"The art of directing the great sources of power in nature for the use and convenience of man, as the means of production and of traffic in states both for external and internal trade."

It is clear that transport is very much concerned with the use and convenience of man and very dependent upon advances in engineering knowledge and practice. It represents about one sixth of the country's economic activity day by day and the few figures set out in Table I will remind us of the importance of transport in our present day economy. Transport is closely related to the needs of human beings not only as passengers but more particularly as consumers and indeed producers of goods either for direct enjoyment or for exchange.

TABLE I
Some Transport Statistics

Staff Engaged: 3,000,000 or 12% of working population.

Costs: Expenditure on Road Transport (excluding road construction and purchase of new vehicles) £37,000,000,000 or 14.9% of national income.

Congestion, estimated cost	£1,000,000,000
British Railways receipts	£474,700,000
British Railways expenditure	£561,600,000
Difference	<u>£86,900,000</u>

Annual Road fatalities .. 7,000

Freight Traffic over 100 miles in 1964
(millions of ton miles)

Road	11,000
Rail	12,000

Planned Mileage of Trunk Routes in 20 years time

Road—in Professor Morgan's study	..	2,700
Rail—routes selected for development	..	3,000

Based on references (2), (4) and (12).

Perhaps more than any other commodity transport is not simply provided in response to a demand but the pattern of transport facilities in an area very much tends to create or shape that demand and thus supply and demand are more closely and intimately related than is normally the case in manufacture.

Some of the more important trends in the development of transport have been identified by the Transport Holding Company⁽¹⁾ as follows:—

(i) “Whereas the objectives of economy and control might seem to be best served by moving towards bigger carrying units, bigger terminal and exchange installations and bigger distribution areas round fewer central points, all these things lead to concentration of traffic and concentration (at any rate in the restricted land areas) leads to a congestion which is the very reverse of economic; on balance, the trend (to which there are exceptions, e.g. where complete automation is possible) will increasingly favour the *smaller-sized carrying unit and terminal* and the *dispersal* of operations.”

(ii) “The economic geography of this small country, with its wide distribution of industry and population dependent not only on certain major arteries, but also— even more—on a close pattern of innumerable “paths” criss crossing, converging and branching off between thousands of pairs of points over relatively short distances, will also favour the pattern of “*small and spread*,” and the more this is so, the less relevant will be those transport techniques which involve really large scale bulking and concentration.”

(iii) “But though the pattern of development will thus be towards “loosening,” there will still be heavy congestion at certain places and times which will call for the employment of techniques offering the greater traffic discipline; some techniques (e.g. railways) provide that discipline more easily than others, but a technique which dragoons people too severely will find employment only while the alternative of *freedom and independence* is not available (e.g. during commuter hours in big cities) and will possess, therefore, a relatively uneconomic basis for existence.”

Transport therefore provides a dichotomy: dispersion versus concentration, and Figure 1 demonstrates two con-

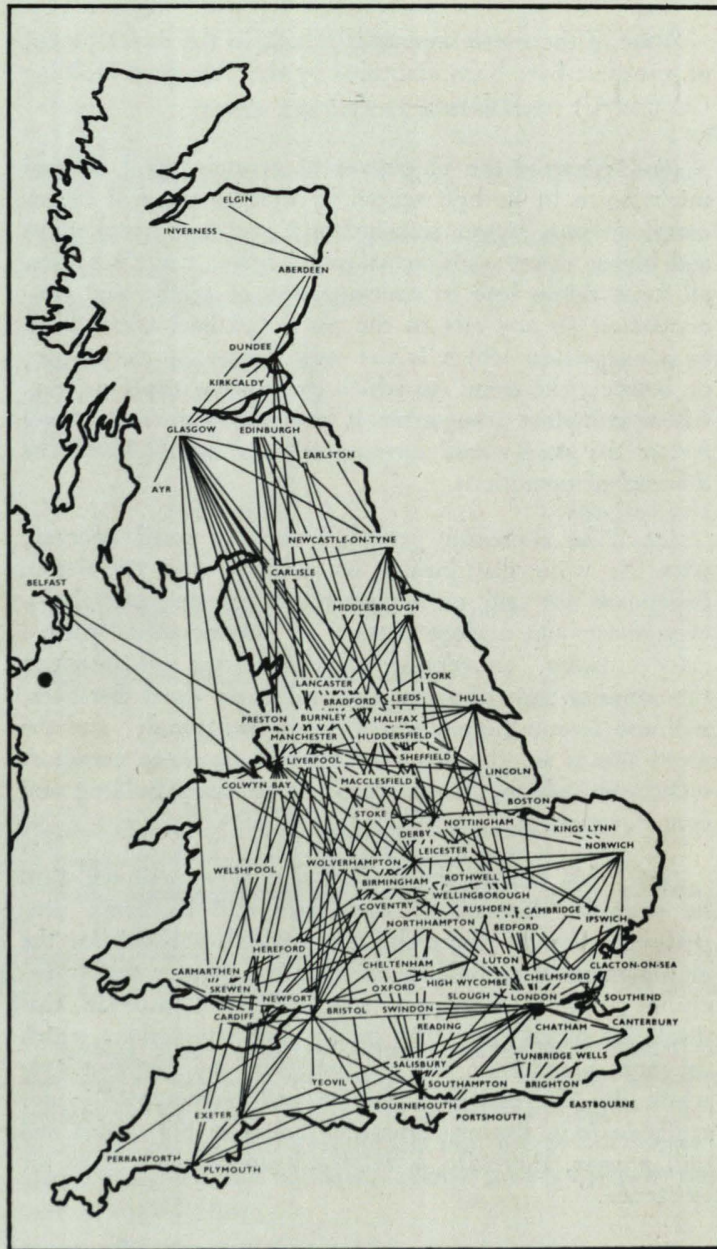

Fig. 1 (a) British Road Service trunk routes for parcels services

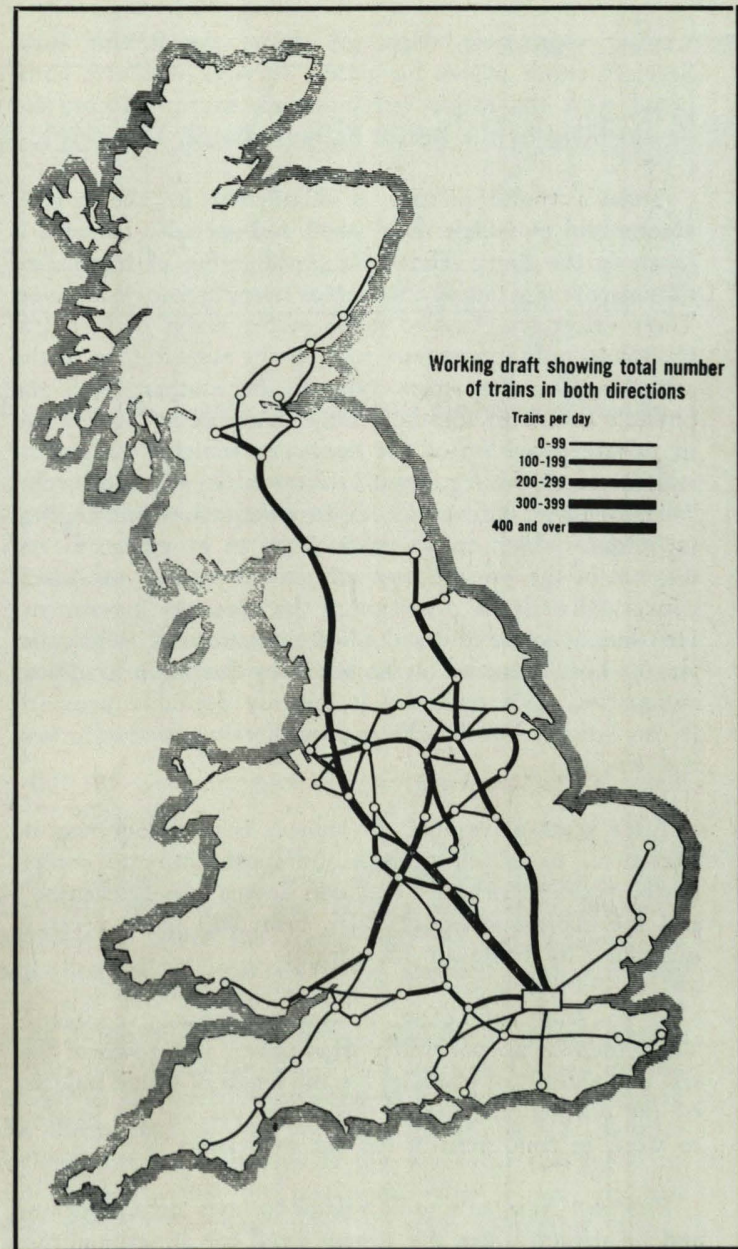

Fig. 1 (b) British railways routes selected for development by 1984

trasting approaches. Map (a) shows the British Road Services trunk routes for parcel services which is compared with the major railway trunk routes selected for development by the British Railways Board, Map (b)⁽²⁾.

Today's traffic picture is dominated by the private automobile in which the "small and spread" concept is taken to the limit. The rapid proliferation of this means of transport is giving rise to serious crises in many countries. These crises arise not so much as the result of technical change in public transport such as the substitution of the aeroplane for the steam railway, but rather from the public's desire to forsake public transport and to engage in private provision of the necessary vehicles without of course corresponding direct investment in way and works. This is a direct outcome of improvements in manufacturing techniques which enable motor cars to be placed at the disposal of the average man without his being too much concerned with the provision of the necessary investment. He thus is enabled to duplicate investment which has already been incurred on his behalf by the public transport authorities. This tendency is entirely desirable provided it can be matched by the appropriate investment in way and works.

After years of neglect the subject is now acquiring its literature, to which perhaps the most dramatic contribution is the report on "Traffic in Towns" by Buchanan⁽³⁾ and the economic aspects have been still more recently quantified by Professor Morgan⁽⁴⁾.

In his study of Leeds, Professor Buchanan concludes "that there is no possibility whatsoever, in a town of this size and nature, of planning for the levels of traffic induced by the unrestricted use of the motor car for the journey to work in conditions of full car ownership."

Professor Morgan's study relates to inter-urban working and he demonstrates the urgent need for an expenditure of some £7 x 10⁹. It is to be noted that even after this

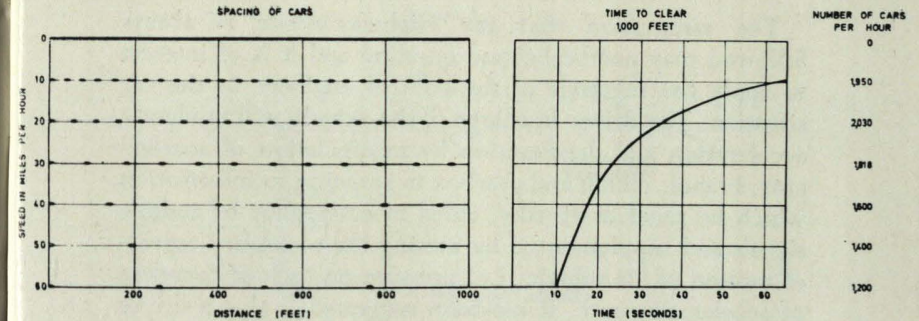

FIG. 2.

Fig. 2. This diagram shows optimum speed for road vehicles

expenditure the standards of speed and comfort will be no higher than they are today. Indeed, if experience in the United States is anything to go on, speed limits of 65 m.p.h. are likely to be imposed.

Consider for a moment the factors which limit the capacity of a given lane of highway. This must depend on

- (a) the behaviour of the individual drivers; and
- (b) the characteristics of the vehicles placed at their disposal.

If a highway is operating at maximum capacity, each lane will be full so that passing will be insufficiently frequent to affect the results and we can consider the behaviour of one car following another as determining the total flow of cars. It will be recalled that advice is given in the Highway Code regarding the minimum spacing of cars for various speeds. If it is assumed that all drivers adhere to this recommendation it is possible to calculate the throughput of cars per hour for any speed. Because braking distance increases as the square of the speed, it can be shown that the maximum value is soon reached after which throughput falls off with increasing speed. Figure 2 illustrates this relationship.

The assumption that the Highway Code is always followed may not be beyond question and it is of interest to apply the methods of the control engineer to the car situation. The driver in charge of the vehicle will moderate acceleration and deceleration by manipulation of accelerator, brakes, clutch and gearbox in response to information which he receives visually, aided in emergency by audible signals and supplemented by sensing the secondary aspects of motion of his vehicle, i.e. pressure on back as correlate of acceleration rate. It has been suggested⁽⁵⁾ that a driver of one car following another responds to a given stimulus in accordance with the relationship.

$$\text{Response} = \text{Sensitivity} \times \text{Stimulus} \dots \dots (1)$$

There will also be a delay or reaction time which we write as T . Thus response at time $t + T$, which can be expressed as an acceleration or braking rate, can be written $\ddot{x}(t + T)$ and set equal to stimulus which is assumed to be proportional to the difference in speed between the two cars multiplied by a constant which has the dimension of speed. The stability or otherwise of the following process was dependent on the value of this constant. Experimental values based on traffic studies in tunnels gave values of 1.6 seconds for T and 19.6 m.p.h. for the constant.

It can be shown by a simple algebraical treatment that there is an optimum speed which corresponds closely with that derived from the Highway Code. Actual values reported by the Road Laboratory on straight roads⁽⁶⁾ are shown in Fig. 3 in comparison with the theoretical result.

It is seen from this that the natural capacity of a lane of the conventional road is something less than 2,000 vehicles per hour. Let us examine the possibilities of increasing this. The most obvious possibility would be to couple a number of vehicles together and place them under the control of a leading vehicle. Thus braking distance could be shared and it can be shown that maximum

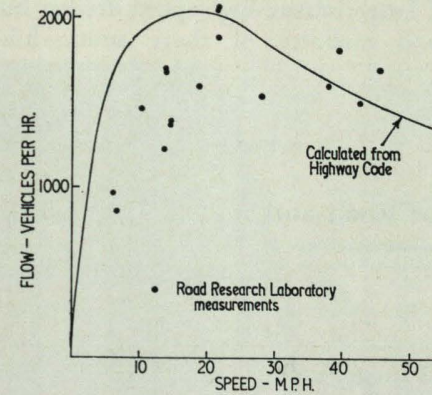

Fig. 3 Comparison of measured with theoretical results for road traffic flow

throughput for any given vehicle length is attained when exactly half the roadway is filled with vehicles and half represented by braking distance.

If, by a flight of imagination, we couple 50 vehicles together and place them under the control of the leading driver we shall increase the capacity of the route some ten times and raise optimum speed to some 120 miles per hour. This is the most important feature of the train. Railway operators often solve problems of congestion by increasing train lengths.

Railway Technology

Let us now consider conventional railway technology, and determine what would be the exact capacity in vehicles on the basis of certain limitations. Table II quantifies the comparison. It will be seen that if automobiles were mounted on trains for the trunk portion of the journey, in the same manner as is now practised for this at Gotthard and Simplon tunnels, and as is proposed for the Channel Tunnel, there would be a considerable economy in route provision. Not only would the routes be more effectively used but drivers would be relieved of

the strain of long distance high speed driving but still have flexibility and mobility of their automobile at their destination.

TABLE II

Capacity of Road and Rail as Limited by Braking

	Road	Rail
Length of Vehicles (ft.) ..	12	20
No. of Vehicles Coupled together	1	70
Braking Deceleration ft/sec/sec	21.5	1.61*
Optimum Speed	15	51
No. of movements/hour ..	2030	50
No. of Vehicles/hour ..	2030	3500
Equivalent No. of Cars/hour ..	2030	5833

*Trains assumed to be controlled by four aspect signals placed 868 feet apart. Sighting distance and overlap each taken as 600 feet.

Railway technology is not standing still, either from the aspects of speed, safety or comfort, although the point must eventually be reached when further improvement may be limited by physical considerations. Regarding speed and excluding avowedly experimental runs such as the French trials at over 200 miles an hour, the fastest regular services on the railway at this time are at 125 miles an hour. It is understood that these speeds are regularly run on the Takiado line in Japan as a preliminary to working up to speeds of 150 miles an hour and the writer has recently had the opportunity of riding on one of the trains which have been put on the regular service between Munich and Augsburg by the German Federal Railways in connection with the International Transport Exhibition



Fig. 4 A German Federal Railways train which operates at 125 m.p.h.

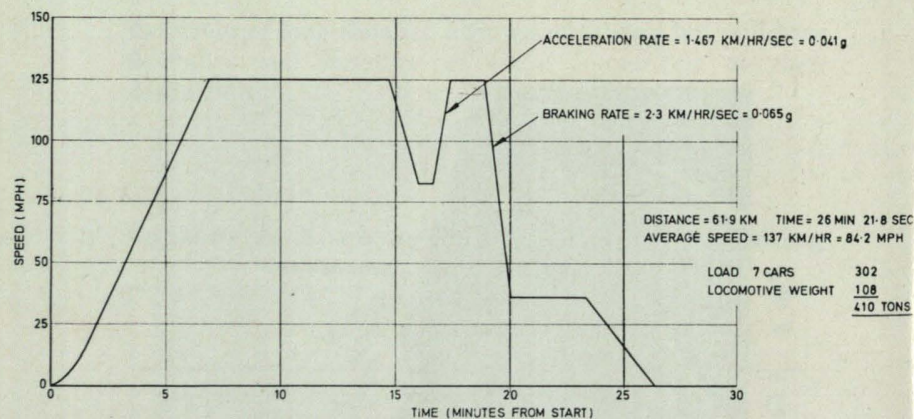

Fig. 5 Speed-time curve of train from Augsburg to Munich

recently held in the former city. (Fig. 4.) Figure 5 shows speedtime curves that are derived from a stop watch with the aid of a tape recorder. It will be noted that there was consistent running at 125 miles an hour but, what is probably of greater note, is the fact that the acceleration was undiminished even at high speed. The facility with which local speed reductions could be carried out will be noted from the dip in the curve which shows the achievement of good braking and acceleration. The acceleration alone corresponds to a drawbar horsepower of approximately 12,000 to which must be added some 2,800 to overcome air and other tractive resistances. Such a horsepower could only be economically provided using an external supply of electric power. Moreover, with a limited speed, the rate of acceleration leads to a relatively short term loading which is a particularly favourable feature of electric traction as compared with diesel traction where the nominal power of the diesel locomotive cannot be exceeded. It will be gathered that the high performance represented by the Munich demonstration can only reasonably be obtained in circumstances where over-load capacity can be available for short periods by drawing on the sources of power available from the general supply industry rather than by attempting to meet the generating requirements on the vehicle itself.

The question whether self-contained or nationally generated power is used on a vehicle is in the first instance an economic one, in so far as with electric traction the motive power units are relatively cheap but an investment has to be provided to enable power to be collected continuously from a fixed source. This investment is rather less than that required to provide track and signalling. The diesel power units are expensive and lack overload capacity. Thus a railway which is lightly loaded with only a few trains will best be dieselised but if traffic is substantial then electrification is the answer. The criterion used in Germany is that a section of railway requiring 300,000 kWh of energy per km spread over the year would justify electrification. This corresponds roughly to a daily carriage of 25-30,000 tons. The French do not issue so simple a statement but it is interesting to note that there with two recent electrifications the electrical demand and loading represented 360,000 kWh and 35,000 tons and 375,000 kWh and 37,000 tons respectively. The extent of electrification on the continent of Europe will be realised when it is noted that on the 12th of March last year the electrification of a section between Ludwigs-hafen and Kaiserslauten completed the link between Dunkirk and Vienna and it was possible to travel from the Arctic Circle to the Baltic and from the North Sea to Sicily by electric train.

If we accept the example of the German Federal Railways 125 miles an hour train as the ultimate expression of present day technology, let us consider the possible limitations to a further extension for that technology. Two fundamental limitations present themselves as follows:

1. The stability of the vehicle and the comfort of the passengers therein.
2. The provision of adequate power to cover the requirements of acceleration and air resistance.

The maximum curvature negotiated at 125 miles an hour was 5,540 feet radius. If superelevation of 6 inches

were provided as in British practices this corresponds to a "deficiency" of $3\frac{1}{2}$ inches. The term "deficiency" used by Civil Engineers can be explained as follows: a vehicle on a curve is subject to a certain centripetal force which is proportional to the square of the peripheral velocity. This force acts horizontally both on the vehicle causing excessive flange forces and on the contents including passengers. The track is therefore tilted or "super-elevated" so that there is a tangential component of gravity acting in opposition to the centrifugal force. When balance is perfect, the passenger is unaware of the centrifugal component because the resultant acts perpendicular to the seat on which he is sitting or the floor on which he is standing. Where balance is not complete the difference between actual superelevation and that required for equilibrium is known as the "deficiency." In British practice this is limited to two inches to which must be added six inches of superelevation. Therefore British practice would have limited speed to 107 m.p.h. on this section of route. However, experimental runs carried out between Crewe and Stafford in order to do research into the dynamic properties of the overhead electric conductors have attained speeds of 119 m.p.h. on curves necessitating deficiency of 5 inches.

Incidentally, these trials represent an excellent example of the unity of engineering. The problem was to electrify a railway which had been constructed many years ago with overbridges having limited clearance. Many bridges were reconstructed to provide clearance for the overhead electric catenary system but the total number was so great that wherever possible the wire was taken under the bridge with very restricted clearance. This provided a dynamic problem because, if the current collecting strip of the pantograph parts company with the conductor wire, arcs will be drawn and in severe cases voltage will drop sufficiently to cause the circuit breaker to open. If this happened too frequently on certain locomotives fitted with Mercury arc rectifiers (now rendered obsolescent by semi-conductor diodes), there was risk of serious mal-

functioning⁽⁷⁾ and damage to the electrical equipment. Thus an electrical requirement could be met either by civil engineering work to raise the bridge or by mechanical engineering research to improve the design of the overhead equipment. In fact the result of the dynamic studies was so favourable that current collection at the bridge became markedly superior to that obtained on open track. Subsequent application of the lessons learned to normal sections of route led not only to improvement in performance but to simplification and cheapening of the equipment⁽⁸⁾. The benefit to be derived from deliberate introduction of damping to the system was demonstrated on the full scale tests and it was shown that this was equally efficacious if applied to the pantograph as to the overhead system, and application of modern control theory, aided by use of an analogue computer, enabled correct ratios of damping to mass to be determined⁽⁹⁾.

Reverting to the question of comfort, the standard achieved by the Bundesbahn at Munich leaves nothing to be desired, but a limit to the speed which can be attained may be imposed in order not to exceed a certain degree of superelevation on the curves to be encountered. Of course, it will always be possible, as at present, to impose speed limits locally but these are always somewhat of a nuisance and should be avoided if possible. Experience with aircraft indicates a high degree of tolerance for "banking" provided that this is correctly adjusted for speed and curvature. Thus, if an increase in gravitational force of 20 per cent can be tolerated, an angle of superelevation of 33.5° may be used. This would enable the limiting speed between Munich and Augsburg to be increased from 125 to 230 miles per hour. Clearly a novel form of guidance would be required to secure stability at this angle.

Periodic forces of far lower intensity than the aforementioned 20% g may give rise to serious discomfort depending on the frequency. Road and rail vehicles are generally fitted with springs giving a static deflection of

between 4 and 8 inches when the vehicle is unloaded. The stiffness to mass ratio is therefore determined within very close limits giving a natural frequency of bounce of 1.11 cycles/second for 8 inches static deflection or 1.56 cycles/second for 4 inches static deflection. It is suggested that this spring stiffness may have been arrived at as a result of empirical adjustment of vehicle design to subjective assessments of comfort. Rocard goes further and relates this to the pace of walking, 1.3 cycles per second corresponding to a static deflection of 6 inches⁽¹⁰⁾.

The problems of vehicle suspension and passenger comfort serve to identify one of the conventional meeting points of the Civil and the Mechanical Engineer. Thus, in railway technology, the Civil Engineer provides the track and the Mechanical Engineer the locomotives and other vehicles that ride thereon. One of the essential features of the conventional railway is the use of comparatively hard material for wheel and rail so that load is transmitted through an area of contact no greater than a sixpence. Although wheels are provided with flanges the vehicle is steered by means of the cone of the tyres. These are normally coned at an angle of 1 in 20. It will be seen that if a vehicle is displaced to the right, then the effective diameter of the wheel on the right will be larger than the effective diameter of the wheel on the left. Therefore as rolling takes place the larger wheel will move forward a greater distance than the left hand wheel inclining the axle so that it moves over to the centre and restores the situation, but clearly this would overshoot and the axle will provide a sinusoidal motion along the track. In certain circumstances the amplitude of lateral oscillation may build up until it becomes limited only by the flanges striking the side of the rails. This situation is known as bogie hunting and can be very distressing to passengers. It does provide, however, an excellent example whereby modern mechanical engineering research into controls and systems as assisted by the Electrical Engineer in the provision of an analogue computer has come to the aid of traditional Mechanical and Civil Engineering in order to

provide designs which are free from trouble in this respect. The simple geometric argument referred to above predicts a motion of constant pitch along the track. Thus the frequency on a time basis increases with vehicle speed which could serve as an exciting force which, if of equal periodicity with the natural frequency of some portion or mode of the vehicle, would excite violent vibrations. If this were the cause of bogie or body hunting one would expect that this would occur only over certain ranges of speed corresponding to the natural frequencies of the various modes of vibration and that quiet running would occur between these ranges. Whilst there is found to be critical speed below which motion is smooth, relief does not always occur as speed is further increased. This was a puzzling feature but enlightenment came from a source which some would not expect but which, if the theme of this lecture is accepted, is entirely to be expected from a unified engineering profession. This source was the aeronautical engineer whose study of flutter of aircraft had given rise to a body of knowledge on dynamic instability which produced results which were entirely consistent with rail vehicle behaviour⁽¹¹⁾.

Although new tyres are usually conical, they often wear to a curved profile, a radius is provided at the flange and the rail profile is made up of several curves. Thus effective conicity varies with lateral motion and stability of the vehicle at speed is determined as much by the rail as by the tyre. This provides a further example of the community of interest of Mechanical and Civil Engineers.

There is a speed at which any particular vehicle—rail combination will become unstable and this must set an eventual limit to the speed of the conventional railway. The superb riding of the Munich - Augsburg trains at 125 m.p.h. indicates that there is some margin in hand and the newly won knowledge offers hope of improved design for high speed so that performance may be satisfactory up to the limits set by curvature. Above a certain speed

however some alternative system of guidance may become necessary both to accommodate high values of super-elevation and to avoid instability.

The energy represented by the unstable motion of vehicles or vehicle components can only come from the motive power provided for propulsion and the mechanism for this can be traced to the frictional behaviour at the interface itself. Thus when two elastic bodies roll together and transmit a tangential force, either longitudinally or transversely, there is a relative motion in the direction of that force which can, as a first approximation, be taken as proportional thereto. This is known as "creep" and is much more pronounced in the case of pneumatic tyres on cars than for steel tyres on railways. It is not surprising therefore that automobiles can exhibit forms of instability which are capable of being resolved using the same principles which have been shown to be applicable to railway vehicles. Thus a car can become unstable above a certain speed or more precisely, the driver has to manipulate his steering wheel more actively to pursue a straight course. This effect can be shown to be related to the creep of the tyres and the position of the centre of gravity. For identical tyres front and back, stability will be assured if the centre of gravity is forward of the geometrical centre of the wheel base. If the rear tyres are inflated to a less degree than the leading tyres, the increased creep may lead to a disastrous loss of "road holding" properties. Thus the condition and degree of inflation of the rear tyres are most important.

Another factor which implies restriction on conventional technology is the adhesion between wheel and track. In the case of the railway this may vary over a ten-fold range (0.05 - 0.5) with consequential hazards to regular operation as far as traction and acceleration is concerned and determining minimum braking distances which set track capacity at a lower value than would otherwise be the case. The traditional method of overcoming low adhesion is to apply sand, but under conditions of high

speed and adverse wind it is virtually impossible to direct sand grains to the contact area. Moreover, sand is a nuisance to the Signal Engineer because it involves risk of maloperation of track circuits and to the Civil Engineer because when used to excess it clogs the ballast and interferes with drainage. It goes without saying that Mechanical Engineers would rather not have 'sand' in the proximity of the complex equipment for which they are responsible. As previously mentioned, in connection with creep, the relative sliding between wheel and rail increases with the peripheral force applied. However, a point is reached when bulk sliding takes place, and as relative speed is further increased, resistance to motion is diminished. Thus, once sliding starts it is apt to increase rapidly.

In the case of locomotives starting from rest this leads to severe damage of the track known as "rail burns." These represent a serious menace because they can lead to failure of the rail by fatigue. Thus, the Civil Engineer is particularly concerned with the degree of control applied to the mechanical equipment. The problem can be tackled by three methods. First and foremost by the control engineer in selecting motive power of the right characteristics so that applied torque falls off more rapidly than friction force as the wheel accelerates and, secondly, by careful measurement of the relative sliding between wheel and rail so as to control the torque applied through a "feed-back" system.

Thirdly, we may attempt to control the variation itself, the reasons for which have not yet been fully elucidated. They are clearly related to environmental factors, particularly weather and contamination. It is well known that the reaction of fatty acids with metals is very dependent on the presence of oxygen and water. Examination of the rail head shows it to be covered with a finely divided powder mainly composed of iron, iron oxide and silica. A possible explanation of the aforementioned wide variation, therefore, may be the interaction of these various components with the fine powder. Thus phase changes

analogous with the change from oil-in-water to the water-in-oil emulsions may affect the effective viscosity of the mixture of matter at the wheel rail interface. This points to the possibility of a chemical treatment of the rail and this is being tried in particularly difficult situations.

Because badly polluted sections of rail are usually localised and because locomotives are usually required to exert full tractive effort at starting or on steep gradients only, it was decided to apply the fluid from apparatus fixed to the track rather than on the locomotive itself. Reliance was placed on the constant passage of wheeled vehicles to carry fluid forward for a considerable distance. The applicator was operated by a plunger which was depressed by the flanges of each wheel as it passed over the section. Because of the need to allow for a wide variation of speed, a special form of pump was devised which allowed a piston to pass downwards with little resistance from the fluid, the main pumping action occurring during the return stroke and the necessary energy stored in a spring. Thus the fluid was expelled from the apparatus in a jet under a pressure which was independent of the speed of the train. The fluid used was a 4% aqueous solution of sodium metasilicate, the action of which was to react with the surface active polluting agents.

Another attempt to solve the problem is being pursued by an international committee. In this case continuous sparking between electrodes and the wheel and rail respectively has been shown to lead to an increase in friction which is believed to arise from the disintegration of organic contaminant.

In the case of the German high speed trains the pre-existing signalling did not allow for sufficient braking distance and had to be supplemented. This provided an opportunity for the introduction of a continuous control system. Cables were laid in the track as illustrated in Figure 6 and fed by current at two frequencies in the vicinity of 3 kilocycles. Thus current was coded to give two in-

dications—the maximum speed and the distance before the train should come to a stop. The cables were looped across the track at 100 metre intervals which enabled position to be determined. The indication in the driver's cab was in the form shown in Figure 7 and it will be noted that in addition to the distance permitted there are two indications: the permitted speed and the actual speed. The driver's task is to keep these two equal and should he fail to do so automatic brake application will occur. This forms a basis for the complete automation of the railway.

As Professor Morgan points out, public transport, with its high labour content, has shown an increase in price well above average. Thus the need for automation becomes self evident.

Let us examine the implications of these facts for the future. Without any great innovation, provision of a single track of railway type equipment with modern signals and motive-power would carry about four times as much traffic as the equivalent motorway at a speed which would be attractive compared with today's surface transport. This can be used provided we can effect a reconciliation of the diffusion-concentration problem mentioned earlier. A simple solution would be to provide automatic roads wherein, during the traversing of the main motorway, the vehicle was entirely under automatic inductive control. Although this has been shown to be technically feasible, the general adoption for public highways is some way off for two principle reasons:

1. The problem of achieving adequate reliability.
2. Problems of getting started arise from having equipment both in the road and the vehicle.

It may therefore be more economical to mount conventional vehicles onto a secondary or ferrying device. This would be less convenient but would offer the advantage of considerably higher speeds.



Fig. 6 Cables used for inductive train communication

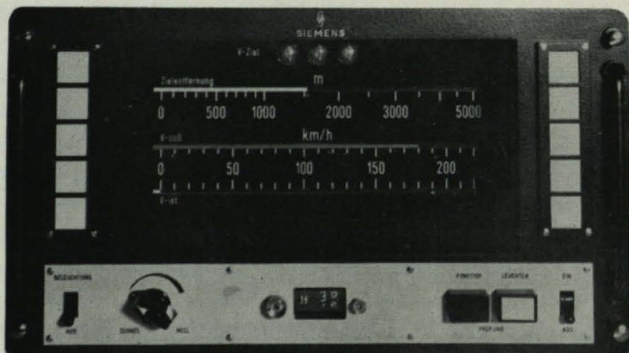

Fig. 7 Indicator in driver's cab showing "distance free," "permitted speed" and "actual speed"

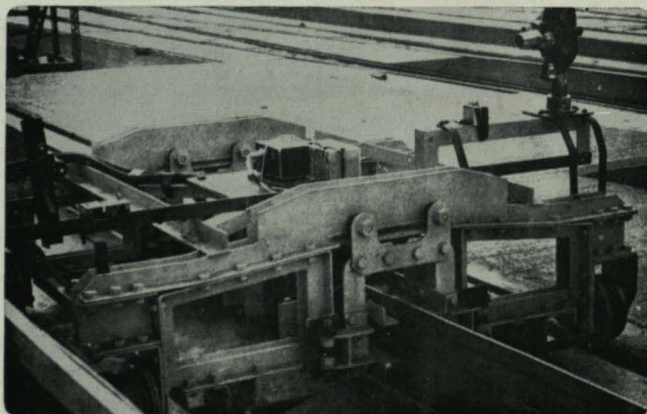

Fig. 8 Linear motor on trial at a British Railway Laboratory

One of the major problems concerned with higher speeds is providing the necessary power to overcome air resistance. Adequate data does not exist, but some idea of the rate of increase with speed will be gathered from figures published by French Railways which give the total power demand of a particular locomotive at 151 miles per hour of 3,000 kilowatts which was increased to 7,500 as speed was raised to 206 miles per hour.

The Linear Motor

A motive power system is required which occupies the minimum cross section to minimise air resistance and low mass to facilitate high rates of acceleration. This seems to lead logically to electric propulsion because, in this case, the heavy equipment for the generation of electrical energy can be placed in a stationary position or indeed power can be taken from national supplies and the only equipment required on the vehicle is used for converting electrical energy into tractive effort. The linear motor is a direct application of Lenz' Law. Normally power is available at a rotating shaft at comparatively high speed and this has to be transformed through gears to a higher torque lower speed range and then through the axles to react with the surface of the track. If, however, we so arrange the mutual position of our electrical and magnetic circuits, a force can be generated in a direction in which we wish to move and thereby the cost and complication of gearing can be eliminated. A vehicle used in practical trials is illustrated in Figure 8 and work, in which Professor Laithwaite of Imperial College is playing a leading part, is continuing. It appears to be an ideal situation here because its characteristics are particularly well adapted to high speed and because it has the minimum of working parts to go wrong. Furthermore, track capacity has been shown to be critically dependent upon the rate of braking which can be achieved and the linear motor is unrivalled in this respect because it is independent of adhesion at the wheel-track surface. Figure 9 shows a possible method of application to conventional railways.

In the case of road vehicles under normal circumstances, it is possible to expect a coefficient of adhesion for rubber which is very much in excess of that which can be generated between steel and steel; this combined with its silence have been put to use in the Paris underground railway leading to a very modern and satisfactory design. However, under adverse weather conditions the rubber tyre on the road is subjected to a very effective form of elasto-hydrodynamic lubrication and coefficients of friction can attain momentarily disastrously low values. Therefore, there is at present no extension of the rubber tyred rail vehicles outside the tunnels of Paris and the skid-risk of rubber tyres will always be a limiting factor in road transport. However, it is the writer's view that a combination of the

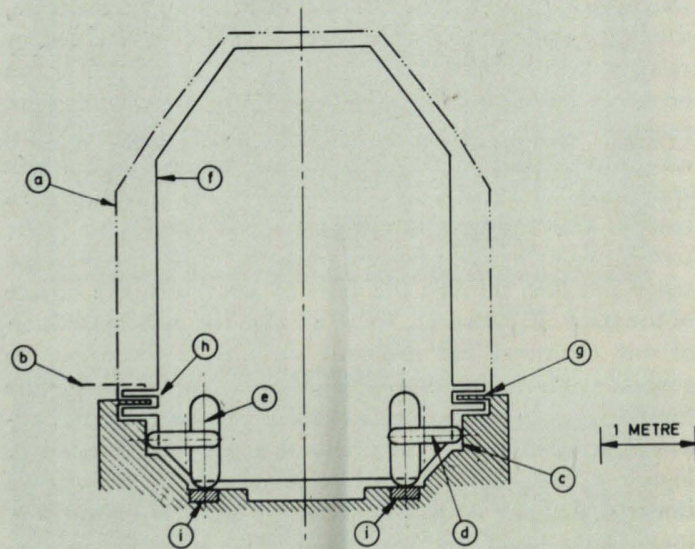

Fig. 9 High speed system related to existing Continental structure gauge. Code: a Minimum structure profile; b Normal platform height; c Vertical space for guidance; d Guiding Wheels; f Maximum vehicle profile; g Reaction plate for linear motor; h Linear motor carried on vehicle; i Track for carrying wheels set outside normal rails

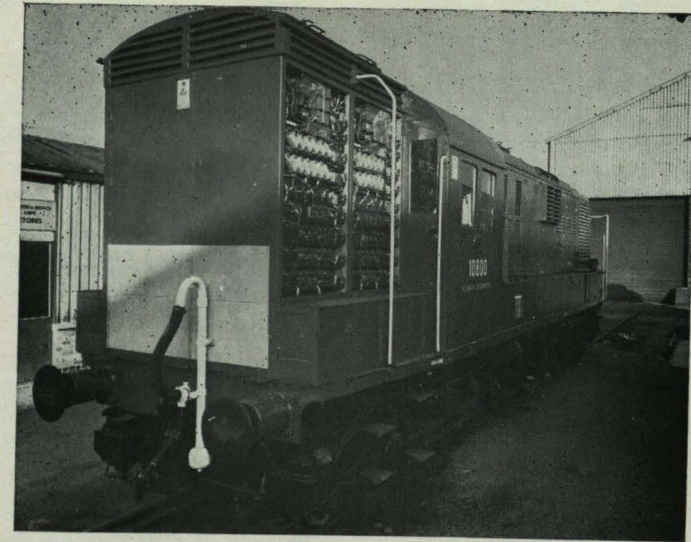

Fig. 10 Diesel electric locomotive with squirrel cage motors

linear motor with rubber tyres on guided vehicles has a tremendous appeal for urban and interurban railways of the future. Figure 9 shows a cross section compatible with an European loading gauge.

Power supply constitutes a problem because it is desirable to adjust frequency to running speed so as to maximise efficiency and because polyphase current is required. The solution can be found, however, in the use of controlled silicon rectifiers which have already been developed to enable conventional induction motors to be supplied from a.d.c. source in traction service. Figure 10 shows a diesel-electric locomotive in which current is generated as a.c., rectified to d.c. and then inverted to polyphase variable frequency current to supply induction motors. These have a simple robust construction and because the control and current converting devices are "solid state," maintenance problems should be radically reduced and, because of the flexibility of the electronic control coupled with the favourable characteristics of the induction motor, maximum possible use can be made of the adhesion.

Ground Effect Vehicles

Proposals have been made that the transport system of the future could be based on the "Hovercraft" or similar means of levitation. In the circumstances where there is no physical contact with the earth, the linear motor provides a particularly favourable form of drive. Whilst the Hovercraft principle reduces friction resisting forward motion, this is not a great problem with high speed transport, friction in bearings and between wheel and rail being very small compared with air resistance, to overcoming which the Hovercraft principle would make no contribution. A good deal of the energy used to overcome air resistance acts to supply momentum to the air. It should not be impossible to arrange to recoup some of this expenditure by arranging for "lift" at the higher speeds. At the lower speeds pneumatic tyres may be useful. The road holding capacity (anti-skid) and the dissipation in friction are both related to the hysteresis in rubber and recent work has produced rubbers with high hysteresis. The above proposal would lead to requests to the rubber technologist to produce a very low hysteresis rubber to minimise power consumption.

The Hovercraft is undoubtedly one of the great transport innovations but its contribution may be to extend the diffuse transport services to a greater extent than it can contribute to economies in the concentrated services. It was mentioned earlier that conventional railway vehicles and tracks are constructed so that normal loads are transmitted through areas which are no greater than a sixpence. Whilst this has led to low friction resistance and complete control, it has also imposed considerable structural demands. The Hovercraft is a complete contrast to this and distributes load over as wide an area as possible. Indeed, one may somewhat facetiously comment that it eliminates the need for civil engineering work altogether. From being a rather ingenious toy, the invention of the flexible skirt by Saunders Roe has brought it into the realm of practical transportation. It is interesting to note that a similar development pioneered by the Societe Bertin and

described at Swansea in the Symposium held in July of last year has received the support of the French Government to the extent of a grant of 3 million francs for development.

One of the most important aspects of any suspension system is its stability as previously mentioned and it is particularly gratifying to find close collaboration between Mechanical and Civil Engineers at Swansea in tackling this aspect of the problem.

City Transport

Whilst the prospects are good for development of high speed inter-city transport, it is within the city and its immediate environment that the traffic is going to be critical in the immediate future.

In the solution of the problem of City transport the electric underground railway is unsurpassed in its capacity for moving a large number of people about in the shortest possible time. (See Figure 11). However, need for tunnelling in cities raises great Civil Engineering problems, particularly bearing in mind the presence of sewers, cables and other services, and the foundations of buildings. Therefore, if it is possible to build upwards carrying the line of route on columns and stilts, advantages will follow. However, conventional railways when so arranged, the so-called "elevated railways", are exceedingly objectionable because of the noise and have virtually disappeared from the American scene. Although the steel wheel-rail combination can be effectively isolated from the passengers by appropriate design and materials, the noise generated externally is difficult to control. Here, therefore, a rubber tyre will have a quite disproportionate advantage in enabling such systems to be erected without the noise hazard. Moreover, it is likely that such a system would require comparatively rapid changes in gradient, for example, connecting up with existing subways and then using an overhead right of way—gradients which would severely tax conventional equipment. Thus the linear motor has something to offer in the range of urban transport although



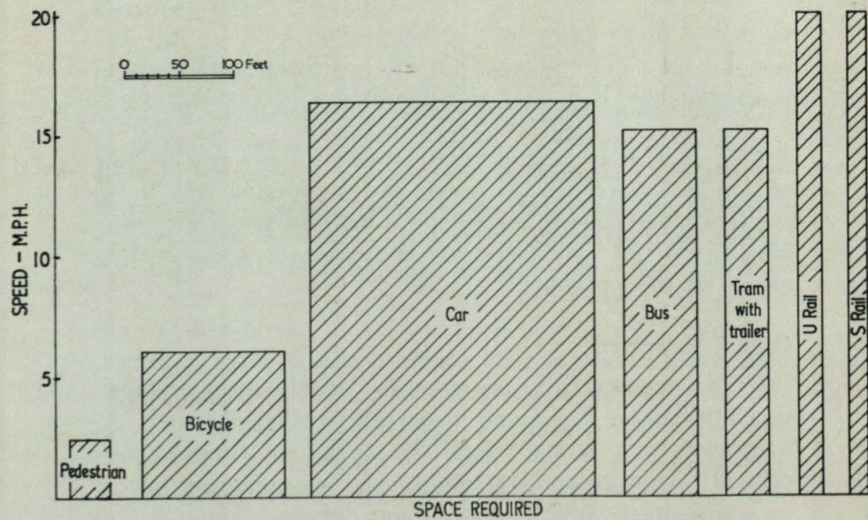

Fig. 11 City of Munich studies of space required for various forms of transport.

speeds achieved are not those which would take advantage of unique characteristics.

If we remove the limitations on acceleration and braking due to wheel track friction limitations, we may be brought up against problems of the physiological reactions of passengers to accelerating and decelerating forces. These have not been sufficiently studied but it seems most likely that change of acceleration rather than acceleration itself may be the important quantity. A passenger can adjust his posture to a uniform acceleration which corresponds to a change in direction and magnitude of the gravitational field in which he finds himself. If this stays constant, he will not experience discomfort. If the direction changes frequently, the constant adjustments will lead to fatigue and perhaps more important, if it changes too rapidly, adjustment may be insufficiently rapid to avoid discomfort or even injury. The limits for normal braking recommended for railway work are 0.14 g with a maximum rate of change of 0.3 g per second. For emergency braking 0.22 g and 1 g per second may be tolerated. The limits for public

service vehicles braking from moderate speed is normally accepted as .5 g although .25 g may cause injury to standing passengers.

Research

It will be gathered from the foregoing that there are many opportunities for the combined efforts of Civil, Electrical and Mechanical Engineers to meet the challenge of transport in the future. Because of limitation of space I have not mentioned air or sea transport although the very great advances in scientific knowledge that have come about through the development of flight are often capable of direct application to land-bound transport.

Areas of research which this opens up can be listed as follows:—

Ergonomics particularly as related to the physical tolerance of passengers;

Vehicle dynamics with particular reference to safety on the road;

Control theory, leading to automation of the rail as well as contributing to road safety to say nothing of more exciting developments such as the linear motor and the Hovercraft.

Other forms of "off the road" locomotion may become of particular importance to developing countries. It is clear that this will make demands on all branches of engineering such as are represented by our own School at Swansea.

It is thus with particular pleasure that I can acknowledge the sound foundations laid by my predecessor, Professor Macmillan, his work on control theory and on mechanical transmissions being especially applicable to the transport theme.

References:—

- (1) Transport Holding Company, Annual Report and Accounts for 1964, p.14.
- (2) The development of the major railway trunk routes, British Railways Board, February, 1965, 15s. od.
- (3) Traffic in Towns, H.M.S.O. 5os. od. 1963, Condensed Edition, Penguin Books, 10s. 6d. 1964.
- (4) Economic and Financial Aspects of Road Improvements, Professor E. Victor Morgan, Roads Campaign Council, October, 1965.
- (5) Herman, R. and Potts, R. B., "Single Line Traffic and Experiment," *Theory of Traffic Flow*, Elsevier.
- (6) Wardrop, J. G., "Experimental Speed-flow relations in a single lane," Proceedings of Second International Symposium on the Theory of Traffic Flow, London, 1963. p.104. O.E.C.D. Paris, 1965.
- (7) Final report on the accidents and failures that occurred in multiple unit electric trains in the Scottish Region and Eastern Region British Railways, Her Majesty's Stationery Office, 1962.
- (8) Sell, R. G., Prince, G. E. and Twine, D., An Experimental Study of the Overhead Contact System for Electric Traction at 25 R.V. Proc.I.Mech.E. Vol. 179, p.765 (1964-65).
- (9) Morris, R. B., The Application of an Analogue Computer to a Problem of Pantograph and Overhead Line Dynamics. (as above).
- (10) Rocard, Y., *Dynamic Instability*, Crosby Lockwood & Sons, London, 1957.
- (11) Bishop, R. E. D., "Some Observations on Linear Theory of Railway Vehicle Instability," Proc.I.Mech.E. Convention on Interaction between Vehicle and Track, November, 1965.
- (12) The Reshaping of British Railways, Her Majesty's Stationery Office, London, 1963.