

LF1217.5, IS 1967

Archives

NUCLEAR POWER  
AND THE  
SYSTEMS ENGINEER

*Inaugural Lecture of the  
Professor of Industrial  
Engineering  
delivered at the College*

by

T. O. JEFFRIES

M.A., D.Phil.(Oxon.), C.Eng., F.I.E.E.



UNIVERSITY COLLEGE OF SWANSEA





Classmark: LF1217.5 I5 1967

Accession no: 67/499

Location: Archives

SWANSEA UNIVERSITY COLLEGE  
LIBRARY

1002423746



UNIVERSITY COLLEGE OF SWANSEA

NUCLEAR POWER  
AND THE  
SYSTEMS ENGINEER

*Inaugural Lecture of the  
Professor of Industrial  
Engineering  
delivered at the College*

*by*

T. O. JEFFRIES

M.A., D.Phil.(Oxon.), C.Eng., F.I.E.E.

(1967)

## NUCLEAR POWER AND THE SYSTEMS ENGINEER

### *Introduction*

**N**UCLEAR power is now producing rather more than 10 per cent of the electricity consumed in Britain (see figure 1). Its development since the war has been one of the success stories of this island and although, commercially, little if any profit has been made by the construction companies, many lessons have been learnt which it is now the duty of the universities to pass on to new generations of students.

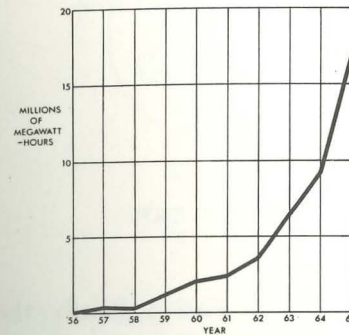

In 1964, Nuclear Power provided approximately 5% of all the electricity generated in the U.K.

Demand for electricity is increasing by about 7% per annum.

Nuclear Power production almost doubled during 1965, providing most of the additional power required.

Fig. 1. U.K. PRODUCTION OF ELECTRICITY FROM NUCLEAR REACTORS.

From the large complex projects of the new industries like Nuclear Power, Defence, Aircraft and Computers has emerged a new discipline of Systems Engineering.

Tonight, I shall explain something of what is involved in building a Nuclear Power Station and why the lessons to be learnt are of particular relevance to the Systems Engineer of the future.

### *What is Nuclear Power?*

In 1939 a discovery was made in Denmark by Frisch and Meitner and independently in Germany by Hahn and Strassman. This discovery was to lead to the spectacular





ending of the second world war and to the prime motivation for much which will occur for the foreseeable future.

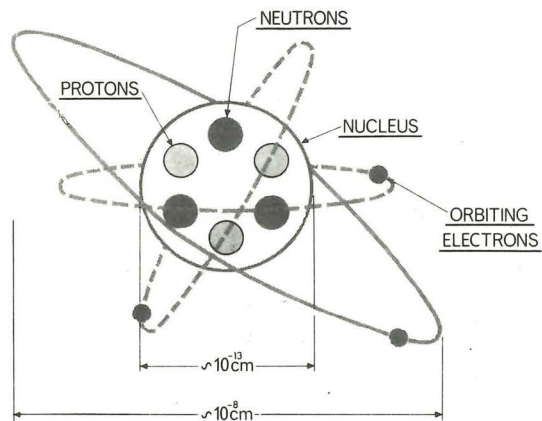

Fig. 2. LITHIUM ATOM (DIAGRAMMATIC ONLY).

The discovery was that of Nuclear Fission. Briefly, the atoms of all the elements had been found as shown in figure 2 to consist of a nucleus built up from electrically positive protons and electrically neutral neutrons of about equal weight surrounded by a cloud of much lighter orbiting electrons. In order to obtain an electrically neutral atom, the number of protons in the nucleus had been equated to the total number of circling electrons which identified the element, endowed it with its chemical properties and defined its atomic number. The number of neutrons, which added nothing to the charge properties, was simply the number necessary to make up the weight of the atom to the measured value.

Atoms with identical chemical properties but differing atomic weights, i.e. isotopes, were then explained as containing equal numbers of protons in their nucleus

but differing in the number of neutrons, and this situation is shown in figure 3 for the lithium nucleus. However, since for any one atom the number of isotopes was always limited to just a few with neighbouring atomic weights, it was clear that the forces binding the neutrons and protons together could only give a stable structure provided approximately the right number of neutrons was present for each element.

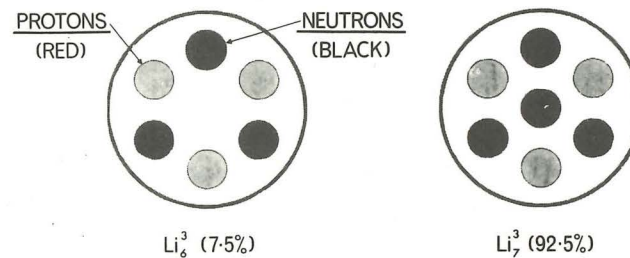

Fig. 3. NUCLEI OF ISOTOPES OF LITHIUM.

The addition of a neutron to the nucleus of an atom would therefore produce an isotope which could be either stable or unstable. If unstable, then the nucleus would disintegrate, usually by one of the neutrons becoming a proton and emitting an electron known as a  $\beta$ -ray. The atom would thus contain one more charged proton than before and hence attract an extra orbiting electron and become a new chemical element of one higher atomic number and unit higher atomic mass.

Now the atomic numbers of elements found in nature range up to 92, ending with the element Uranium which exists as two isotopes with weights 235 and 238. Natural Uranium which is a mixture of them is already weakly radioactive, indicating that one of the nuclei is already slightly over the stability borderline. The discovery of 1938 was that addition of a neutron to  $U_{235}^{92}$  does not lead

to  $\beta$ -decay into the next element  $X_{236}^{93}$  but to a complete disintegration of the Uranium nucleus into two nuclei of much lower atomic number. The important features of this disintegration are:

- (1) Considerable energy is produced in the process – the fission of one atom of Uranium gives sixty million times the energy of combining one atom of Carbon with Oxygen as happens when coal is burned.

This energy appears as heat in the bulk of the Uranium.

- (2) The elements of lower atomic number produced in the fission process require less neutrons per proton for stability. Hence a few neutrons are spare and these are emitted with considerable velocities.
- (3) A small fraction of the neutrons produced are delayed, i.e. they do not appear immediately the fission occurs, but at times from  $\frac{1}{2}$  sec. to 1 min. afterwards.

As a consequence of (2) a chain reaction is possible. If the neutrons produced from the fission of one Uranium  $235$  nucleus can be induced to enter further atoms of Uranium  $235$ , these will disintegrate, producing second generation neutrons to enter even more atoms of Uranium. In each disintegration considerable energy is produced, the whole of the Uranium will finally become very hot and, if the heat can be removed, it can be put to useful purposes. The fission process is illustrated in figure 4.

That a chain reaction might be possible was clearly realised soon after the discovery of a fission process and in 1939, Meitner and Frisch working with Bohr and

Fermi established its practicability. In the same year, Joliot, Halban and Kowarski took out French patents in Switzerland for a Uranium reactor. However, initial work was almost entirely concentrated on producing a reaction which would give an explosion. It was in the course of this work that the world's first nuclear reactor was constructed in Chicago by Enrico Fermi and went critical on 2, December 1942. That is to say, a self sustaining nuclear fission chain reaction was produced by man for the first time on that day.

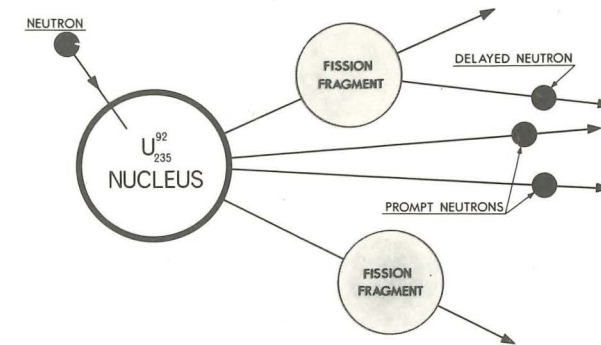

Fig. 4. FISSION PROCESS (DIAGRAMMATIC).

How is it that nuclear fission can be used successfully in a bomb, yet can be controlled safely in a nuclear reactor to produce useful power? The answer lies in the third point that I made above. Some of the neutrons are delayed. The effect of this is shown in figure 5. For the chain reaction to proceed at a constant rate, each generation of neutrons must contain the same number. In other words for every neutron which produces fission, one of the resulting neutrons must also produce fission and any others produced must be absorbed without producing fission. In this condition, if 99 per cent of the neutrons are produced instantaneously and 1 per cent are produced with a considerable delay, small changes in the reaction



rate depend on this latter 1 per cent and for small changes in power the reactor has a time constant governed by the delay times of the 1 per cent thus giving ample time to correct any small fluctuations by adjusting the position of neutron absorbing rods inserted in the reactor. If, however, the power level is increased so that 101 neutrons are produced for every 100 neutrons absorbed,

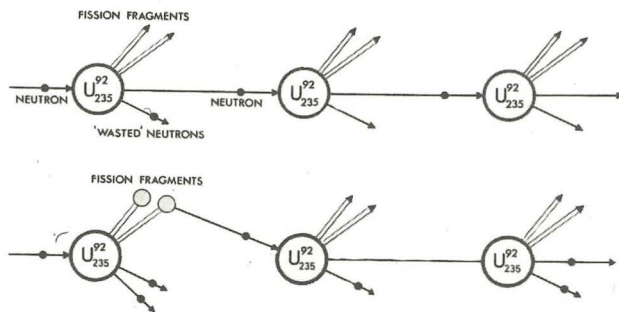

Fig. 5. FISSION CHAIN REACTIONS SHOWING PROMPT CHAIN (UPPER FIGURE) AND DELAYED CHAIN (LOWER FIGURE).

then 100 of these are produced instantaneously, these produce a further 100 instantaneously and so on, and the reactor is said to be prompt critical, not needing the delayed neutrons to sustain the reaction. Power changes now occur with a time constant governed by the emission time of the instantaneous neutrons, i.e. a time constant which is very small indeed. Under these circumstances the reaction becomes explosive and all that is needed to create a bomb is to arrange for a sufficiently high reproduction rate for the neutrons to exist for a sufficient time.

Fortunately this is not easy to do. The fissile isotope in natural Uranium is  $U_{235}$  and only 0.7 per cent of the atoms are of this type. Furthermore, the other isotopes absorb neutrons but do not produce fission and so, effectively poison the system. To produce a bomb,

almost pure  $U_{235}$  was needed and the separation process is so expensive that power produced from such material would be wildly uneconomic. Some other solution is needed. Now although the proportion of  $U_{235}$  in natural Uranium is small, its ability to absorb neutrons is greater than that of  $U_{238}$  and this is particularly so at very low neutron velocities. Hence, if the fast neutrons produced

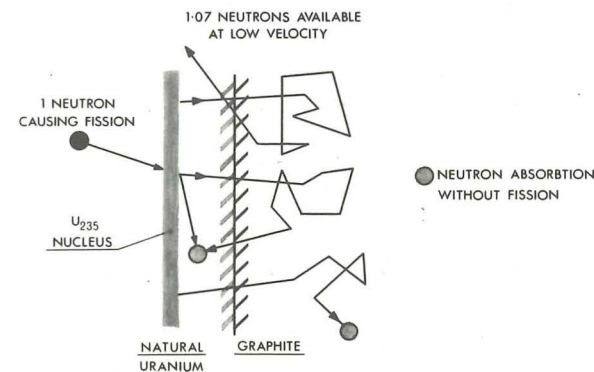

Fig. 6. DIAGRAM OF NEUTRON ECONOMY IN A NATURAL URANIUM/GRAPHITE ASSEMBLY.

in the fission can be slowed down sufficiently before being allowed to react with the natural Uranium, there might be sufficient reactions resulting in fission to provide more than one neutron for each neutron absorbed. In fact this turns out to be so and if the neutrons are slowed in lumps of graphite, it is possible to produce about 1.07 neutrons for each neutron absorbed. This process is illustrated in figure 6. This number of 1.07 does not allow for neutrons which escape from the reacting assembly altogether, nor does it allow for additional poisoning effects which occur, because the fission fragments, the products of the reaction itself, themselves produce very potent poisons. In practice, for the reactors generating power in this country, about half the spare 7 per cent is taken up by these poisons and the reactors

are then designed so that their surface to volume ratio is small enough to reduce the leakage to a figure just below the remaining  $3\frac{1}{2}$  per cent. Typical dimensions for such a reactor are a cylinder 45 ft. in diameter x 25 ft. high. Thus you can see that the design is very near the bone and 1 per cent less in the number of neutrons available would have made the use of natural Uranium in graphite assemblies impractical because of the large sizes necessary and the resulting poor economics of the system.

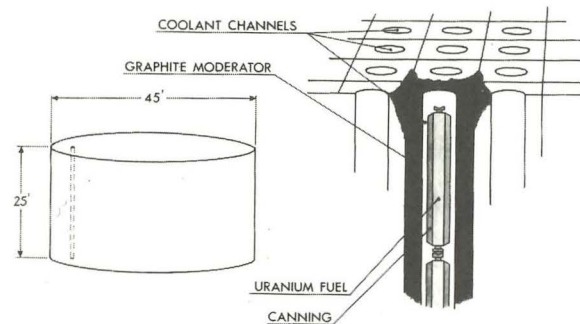

Fig. 7. DIAGRAM AND SECTION OF A NUCLEAR REACTOR.

#### *The development of Nuclear Power*

The requirements of a nuclear reactor using natural Uranium are summarised in figure 7.

The Uranium is placed in discrete lumps, which for manufacturing and heat removal convenience are made cylindrical, inside a material, in this case graphite, which has the property of slowing the neutrons down without absorbing them. Since the whole purpose of the reaction is to produce heat, some means for its removal and use must be provided. This is done by leaving a gap around the Uranium fuel through which a coolant gas can be blown to remove the heat and transfer it via heat exchangers to produce steam to drive turbines. That some system like this would possibly work was known in 1945 at the end of the war. Fermi's Chicago experiment had proved that natural Uranium in a graphite moderator

would make a critical system at low power. Some of the techniques used for producing the bomb had further confirmed that power could be obtained. What were completely unknown were the economics of the process, the optimum arrangement of fuel and moderator, the life of the fuel and many questions of safety.

What was evident was that the demands for power by future generations would increase at a very considerable rate. Coal resources in Britain had a predicted life of only 200 years and the incremental cost of additional output promised to be very considerable. Oil resources of the world had a lower incremental cost than coal, though in total they were available in less quantities and at the end of six years of war, dependence on outside power supplies looked even less attractive than it does today. The government of the day decided that Nuclear Power should be exploited and in 1947 set up research headquarters under the Ministry of Supply on an old airfield at Harwell in Berkshire. At about this time many of the scientists and engineers who had worked both in Britain and in America during the war, were returning to this country and their knowledge formed the basis upon which the first commercial nuclear power station in the world was developed and built.

Much work had to be done. Zero energy reactors were built to give data on the nuclear processes, high flux reactors were constructed to determine the effects of neutrons and radiation on materials. Exponential assemblies supplied critical physics data and large heat transfer rigs were used to determine the form of the fuel elements. Extensive theoretical work examined alternative steam cycles, reactor core arrangements and reactor safety problems.

By 1953 enough of these basic physical and materials problems had been solved for the decision to be taken to go ahead with the world's first nuclear power station



designed to give a useful electrical output for public consumption in addition to producing plutonium as an additional source of fissionable material, and the construction of a natural Uranium, graphite moderated, gas-cooled system was started. Natural Uranium was chosen despite the technical difficulties mentioned earlier because cost was of prime importance and nuclear power was only attractive if the unit cost was at least within striking distance of the unit cost of power from coal fired stations. Graphite was again chosen on a cost basis and also because the gas cooled, solid moderator, Uranium metal system was believed to be inherently safe. The gas chosen was Carbon Dioxide which although not technically quite as good as Helium, was readily available in Britain and, again, considerably less costly than Helium.

The site chosen for this first reactor system was Calder Hall, near Seascale in Cumberland. This was already an atomic site, having in operation some earlier, air-cooled, reactors, built as plutonium plants.

In order to use the heat from the reactor it is necessary to pass coolant gas over the fuel and thence to a heat exchanger in which water can be converted to steam to operate a steam turbine. For reasons of efficiency, safety, and economy the gas must flow in a closed system and to achieve adequate heat transfer, this system must be pressurised. This provided a new problem and since there was no experience in Britain of site welding steel plates of a thickness greater than 2 inches this thickness was chosen for the vessel and set a limit to the reactor size and working pressure. Even so, the decision to weld 2 inch plate on site to form a 37 ft. diameter cylindrical pressure vessel involved the development and implementation of several new techniques such as on-site X-ray inspection of all welds, methods of stress relief and of pressure testing. Many other novel equipments had to be designed for Calder Hall. Fuelling Machinery was necessary to remove old fuel from the reactor channels,

deep within the pressure vessel, and convey it safely, without radiation hazard to personnel, to a pond where it could lie undisturbed until, in terms of radiation, it had become cool enough to handle. This machine had also to load the new elements into the channels from which the spent fuel had come.

Burst Cartridge Detection equipment was needed so that any radioactivity in the gas, indicating a burst in one of the Magnox containers, could be detected and the offending channel located so that the faulty element could be removed.

Variable speed blowers were required, capable of blowing about 600 lbs/CO<sub>2</sub>/sec. at a pressure of 100 lbs./sq. in. and a temperature of about 200 deg. C.

Even the turbines had to work in conditions which were nearer those of 30 years earlier, for the temperature of the steam leaving the heat exchanger was only 600 deg. F. whereas that of the modern high pressure boilers had already reached 1000 deg. F. in the 1950's.

On top of these problems of design, the construction engineers faced a completely new one, that of clean conditions. On a half completed power station site, amidst all the mud and rubble, it was necessary for the whole interior of the pressure circuit to be almost clinically clean for the building of the reactor core. This was absolutely essential since the presence of only minute quantities of some materials could have prevented the reactor being started at all and most substances could have neutron poisoning or deleterious metallurgical effects on the fuel elements or other reactor components. By the establishment of change rooms, rigorous search routines and careful inventory conditions, all dirt was excluded from the circuit and all tools and equipment entering the vessel were retrieved or accounted for.

But the real triumph was not in solving any one problem but in solving them all to a very tight construction programme. Calder Hall was in fact completed on



schedule and in 1956 became the first commercial nuclear power station in operation in the world. So ended the first phase of the development programme. Figures 8 to 12 are of later stations in which I was myself involved and serve to illustrate the points I have made.

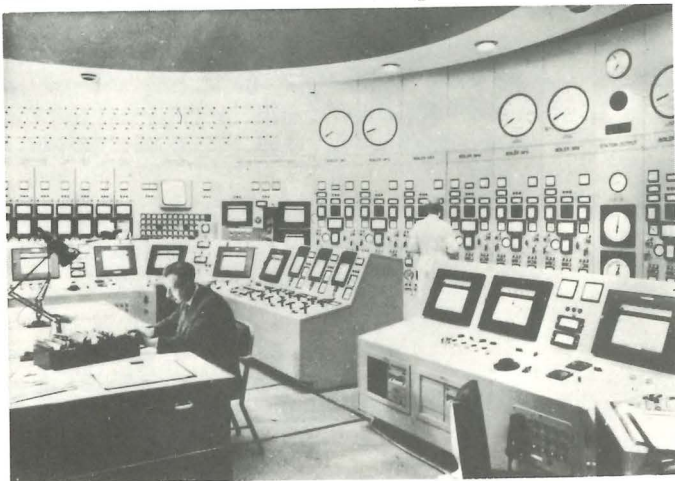

Fig. 8. NUCLEAR POWER STATION CONTROL ROOM.

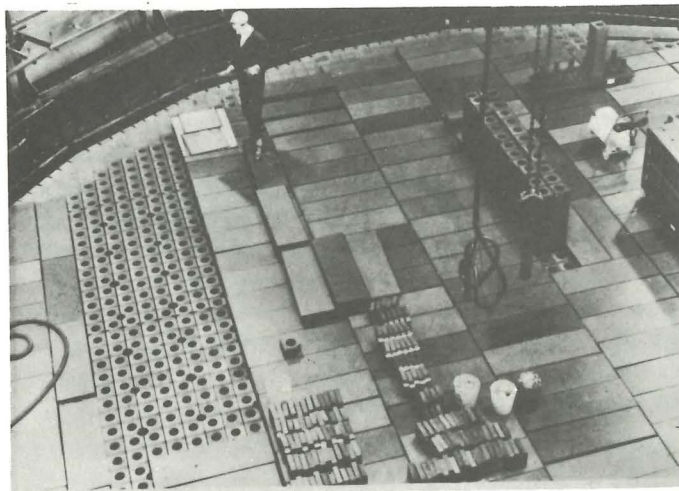

Fig. 9. GRAPHITE LAYING.

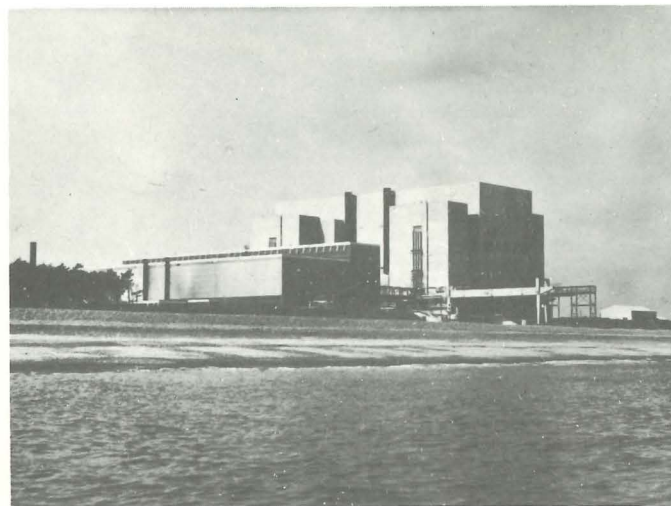

Fig. 10. SIZEWELL NUCLEAR POWER STATION.

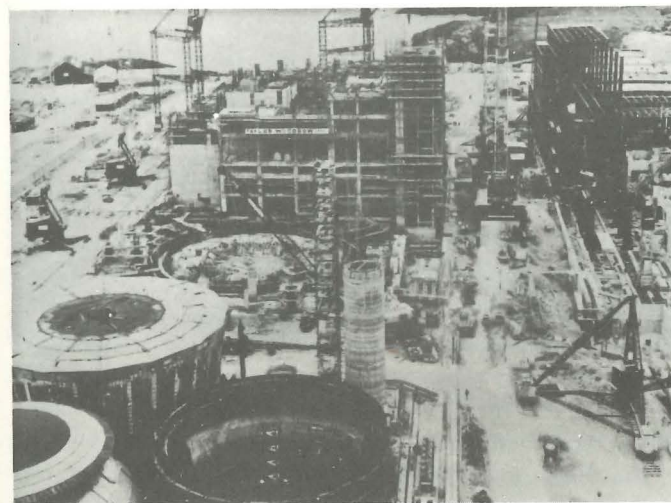

Fig. 11. A NUCLEAR CONSTRUCTION SITE.



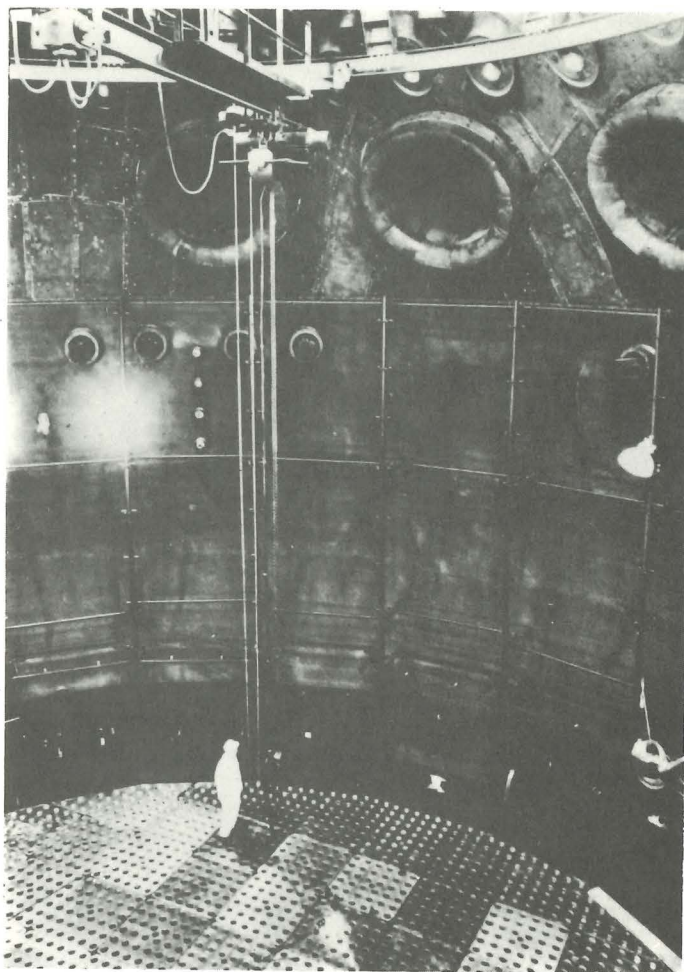

Fig. 12. INSIDE A REACTOR PRESSURE VESSEL.

The second phase opened with the issuing of enquiries by the Electricity Authority for civil stations. Calder itself was fairly small, being designed primarily as a plutonium producer and with an electrical output of only 45M.W., and it was not therefore possible to draw

direct conclusions from it about the economics of nuclear power. On the other hand, the correctness of the technical calculations could be checked and estimates made of the likely cost of nuclear power from a station designed specifically for that purpose. Such estimates showed near competitiveness with conventional fuels and led to the proposal that the Central Electricity Authority should start the construction of a number of similar but larger stations based on natural Uranium, magnox casing, and graphite moderator.

Indeed, because of the likely success of Calder, the major electrical manufacturers in the country had already been invited to form themselves into consortia with established boiler-makers and civil engineering firms in order to tender for comprehensive contracts for the design, development, construction and commissioning of complete nuclear power stations for the Authority. It must be understood that this was a complete departure from previous Authority procedure for conventional stations. It had been the custom, and still is for conventional stations, that the Electricity Authority, together with engineering consultants, should undertake the design of the station themselves. The component parts such as turbines, boilers, etc. would then be tendered for by the manufacturers and the whole project organisation would be handled by the Authority.

In the case of nuclear power, this procedure was abandoned for a variety of reasons. First, the design of a nuclear power station, demanding machinery, even on the conventional side (e.g. turbines), which was radically different from that in production, seemed to need a much closer integration of the firms manufacturing and designing the equipment. The optimisation of the station needed consideration to be given not only to the reactor but also to the boilers, the blowers, and the turbines and this consideration had to be of what was practicable, not of what was readily available.



In fact, the nuclear power station was an example of a complex system and the Electricity Authority were tacitly acknowledging this fact by their action. Many of the men who designed Calder Hall would nowadays be known as systems engineers. Their task was to see the project as a whole, to weigh the competing demands of civil, mechanical and electrical engineers, of cost and time, of the easy expensive solution against the difficult cheap one. These men had not been trained as systems engineers, their success depended in large measure on their wide experience as practising engineers in other fields.

Nevertheless, no one would pretend that Calder Hall was an optimum design for power production. It was a prototype and as a prototype it proved a point. The men who built it made mistakes and learnt from their mistakes. Its successful completion was a great achievement and we can learn from their success as well as from their mistakes.

It is inevitably the job of the educator to teach the men and women of tomorrow those things which will stop them making the mistakes of yesterday; to replace experience by learning so that the starting point in their life is a step further forward than that of their fathers' generation and so that from this improved position the new generation can advance further than the old.

But nuclear power is not the only systems industry. A system is, in fact, any interconnected set of components performing a useful function and clearly there are many examples. A radio receiver is a system, so is a motor car. Both of these examples had been in production for many decades. Why has the term 'systems engineering' appeared relatively recently? What is it that makes a nuclear power study yield conclusions different from, say, a study of missile systems or aircraft systems? What are the indus-

tries in which we can expect to find systems engineers and what will the systems engineer do? Let us consider these points.

First, systems engineering has emerged as a distinct subject from those industries involved with large systems, where a large system is one where the number of parameters at the disposal of the designer is large. The problem of the systems engineer is that of choosing the values of these parameters to give the cheapest adequate solution at the right time and this problem derives much of its difficulty from the interaction of time and money. The problem is not merely the (by no means easy) mathematical problem of finding the minimum cost in the  $n + 1$  dimensional space consisting of the cost and the  $n$  disposable parameters' It includes the genuine exercise of engineering judgment of the best means of achieving the results and of the organisation most likely to be effective. The need for the systems engineer is felt where the system is too complex for either the management or the detailed design or development engineers to see the solution and too costly to run a serious risk of making a mistake.

Secondly, why study nuclear power rather than the somewhat older Defence systems and aircraft systems industries? In what essential ways does it differ? Primarily these differences lie in the fact that nuclear power has, from the start, been required to be commercially viable; that no cost-plus contracts were awarded for building nuclear power stations. True, prototypes were constructed by the Atomic Energy Authority using government money; true, the basic data on much of the physics and materials properties were obtained in government research laboratories; but these prototypes were to prove a principle; in no case that I know was a single production drawing from the Atomic Energy Authority of any use to the industrial consortia tendering to the Electricity Authority. The research work established basic facts -



those that would have become available, in the normal course of events, if development could have been slower. In all cases the specific information such as heat transfer coefficients for fuel elements, neutron flux shapes, kinetic behaviour of the systems and flux levels outside shielding had to be determined either experimentally or theoretically, by the firm concerned within the contract which they had won in competition.

This competitive nature of nuclear power station contracting changes the emphasis placed on time and money factors as parameters and leads to a greater striving for efficiency than cost plus working or defence development contracts normally do. As the computer industry grows and the aircraft industry (by government edict) tries to become more competitive, so the lessons of competitive systems engineering become the relevant ones to be learnt by the prospective employees of all these industries.

Other differences of some importance exist as well. For instance, the cost of a single nuclear power station may be as high as £100,000,000 and, to date, there has been little replication. For much of the station, production line techniques are not appropriate. Equipment must be custom built and with the present awarding of contracts, the load on any particular facility is very peaky. Construction times are about five years and so rapid is the development and the introduction of new ideas that usually a consortium which is awarded its next contract before it has completed and proved its design in the current one, is involved in including major changes to designs which have not in practice been proved satisfactory or otherwise. No one would claim that this situation is ideal. In a competitive field, it is difficult and at times promises to be disastrous. Nevertheless, it differs from that of many other industries and its lessons will also be different.

Thus in many ways, a study of systems engineering in the nuclear power industry will reveal results of importance in the new era of fast developing competitive, complex systems projects. Among such projects receiving particular emphasis at present are the wide variety of automation schemes using digital computers as their nerve centre. Indeed, nuclear power stations themselves use a degree of automation not yet achieved in conventional stations.

These last remarks really answer my third question: 'Where will systems engineers be employed?' Many of them will become the design and project engineers involved in the planning and controlling of the installation of automation into a wide variety of process industries. They will be employed either by the computer companies as applications engineers or by the process industries as project engineers.

This is the primary role of the systems engineer but in no way is it exclusive. Systems engineers will find their way, effectively, into many industries besides the traditional systems industries already mentioned and the new computer industry. Their education will fit them for positions throughout industry where the ability to see the wood for the trees, to balance timescale against cost and the rival claims of different disciplines against one another are of prime importance. Indeed, any industry that claimed it had no need for these skills must surely be too self-satisfied to survive.

The final question was 'What will a systems engineer do?' and this I will try to answer by reference to the early part of my lecture on nuclear power.

A nuclear power station is not only a system; it is itself a sub-system of the generating network of the country and it can in turn be split up into smaller sub-systems. One of the first jobs to be done when thinking of a power station is to consider where it fits into the total system, to consider load demand predictions and





system security, fuel and water resources and possible sites and by consideration of both direct and indirect costs during the life of the station to choose the site and type of station which will lead to the minimum cost system for the desired security of supply. This is a systems engineer's job carried out now by the Central Electricity Generating Board (C.E.G.B.).

Let us now suppose that the choice is a nuclear power station. An enquiry will be drawn up by the C.E.G.B. stating the specifications which must be met if the station is to fulfil its proposed role in the system. Other requirements such as equipment standards will also be stated so that maintenance requirements and spares are minimised. The specification writing is also a systems engineer's job, though here, experts in specialist fields will be called in: the physicist to advise on reactor requirements and radiation levels, the electrical engineer to advise on generators, the mechanical engineer to specify the turbine and so on. The systems engineer's job is to ensure the compatibility of the various demands and to compromise between the desirable provisions and the likely cost.

When the consortium receives the enquiry it will start to put together a tender. It will consider possible layouts of the station using 'order of magnitude' figures for the sizes of various components. To ensure that all requirements are met a project engineer or manager is usually appointed at this stage and this man must be a systems engineer. He will break the station into a number of smaller systems such as the reactor system, the fuelling system, the burst cartridge detection system, the thermodynamic system etc. These will then be studied as systems in their own right. The specifications to which each team work are set by the project engineer with reference to the C.E.G.B. enquiry and the requirements of the other teams. As work proceeds, so specifications become more and more firm until finally a tender can be written.

At this stage, much of the work can be described as 'optimisation'. The design likely to lead to the cheapest construction is being sought. In the reactor system for instance, the effect of varying channel diameter and spacing, of changing heat transfer surfaces on fuel elements, of changing graphite quality, of varying mass flow and inlet and outlet temperatures, of varying pressure vessel thickness and working pressure and of many other changes is studied. The physicist performs the core calculations, the mechanical or chemical engineer determines the heat transfer coefficients and friction factors, the metallurgist calculates the effect of changing temperatures on the various materials. The systems engineer considers the results from all these disciplines, asks for additional work in critical areas or where needs clash and finally decides the likely minimum cost system. In doing this he needs to make allowance for errors in the calculations and for unknown factors which might yet appear. He must be wary of the type of optimum where a small adverse alteration in one parameter could cause disproportionate escalation in cost. He may well choose an off-optimum design because in his judgement the risk of such catastrophic change is too great. He is performing an engineering task which sets the scene for all the operations to follow. On the decisions made at this time depend the probability of obtaining the contract and that of successfully completing the job. The profit or loss on the job can often be traced directly to good or bad systems engineering at this stage.

Before a tender can be written, the kinetics of the system will also be studied. Whereas the static optimisation usually takes place for full load conditions and makes extensive use of digital computers to produce curves of cost versus each parameter, the kinetic study often is carried out on an analogue computer and the optimum values of control system parameters to achieve system stability and safe operation under fault conditions are



determined. In both cases it is necessary to express the system variables in a logical quantitative language which is, of course, mathematics, and the process of representing the system as a set of equations is generally termed mathematical modelling.

Suppose now that a tenderer has been successful and that a contract has been awarded. A wide variety of operations must now take place. Pre-tender calculations must be refined, detailed design work must start, development of novel features must proceed. All this work needs to be planned and co-ordinated if time and money are not to be wasted. The project engineer will be responsible for seeing that this is done. He and his assistants will be involved in settling all points of contention in the plan and thereafter in ensuring that it is met. He is the systems engineer responsible for the whole system – the power station. The sub-systems of the main system, themselves large and complex by many standards, will be in the hands of section leader designers leading teams of engineers carrying out the actual design and often relying on service sections to provide technical data and carry out the more complex calculations. The section leader designer is essentially a systems engineer and his team will contain at least one or two systems men also. At this point the detailed organisation of the company matters. If promotion is to be from within a team and the team leader needs to be a systems engineer, the only members of the team eligible for this promotion are the systems engineers! Clearly this situation does not at present hold, for the number of trained systems engineers is too small to fill even all the section leader posts. In the future, other things being equal, the systems engineer in this type of organisation will have the edge on other engineers of the same age and of comparable ability. He will have been taught that which the others must learn by experience.

There is, however, another type of organisation which avoids many of these difficulties. Systems engineers form

a team who decide the detailed specifications of the elements of the system. The detailed design engineers then work to these specifications and, provided they meet them, the system as a whole will function. This sort of organisation in addition to avoiding the problems of career prospects, leaves the systems engineer free of the problems of organising detailed design but substitutes the difficulty of lack of experience feed-back, particularly serious where engineers learn largely by experience but less so when teaching replaces experience. As systems engineering teaching increases in this country, this alternative organisation may well find favour as a practical solution to organisational difficulties.

What then have we learned about a systems engineer's duties? He is very involved in optimisation and this means that he must be skilled in mathematical modelling, simulation, and the use of computers. At the very centre of his work is the parameter of likely cost, judged in terms of direct and indirect charges on the project in both favourable and adverse circumstances. So economics plays a large part in his work. He needs to be able to plan and control a project. The techniques of engineering management must be at his command.

These are his duties in a nuclear power station design team. They differ little in other industries.

Ladies and gentlemen, we are on the threshold of a second industrial revolution and it is the systems engineers who will have the major technological task in bringing it about. These are the men who must replace the inventors of the first revolution, who must replace the ad hoc inventive genius of Arkwright and Watt by a systematic technology; who by a planned and logical approach will solve problems far more complex than those of the eighteenth and nineteenth centuries and who, when their acquired skills successfully marry with innate ability will make computers and hence themselves the masters of all they survey.



Acknowledgment is made to the English Electric Company Limited  
for permission to reproduce the photographs on pages 14, 15 and 16.

Published by the  
University College of Swansea, Singleton Park, Swansea

